

RHM 40

Coriolis Mass Flow Meter for Demanding Applications

General Flow Control / Plant Balance / Terminal Transfer / Mixing
and Batching / High Temperature Fluids / Barge, Ship, Rail Car and
Truck Filing

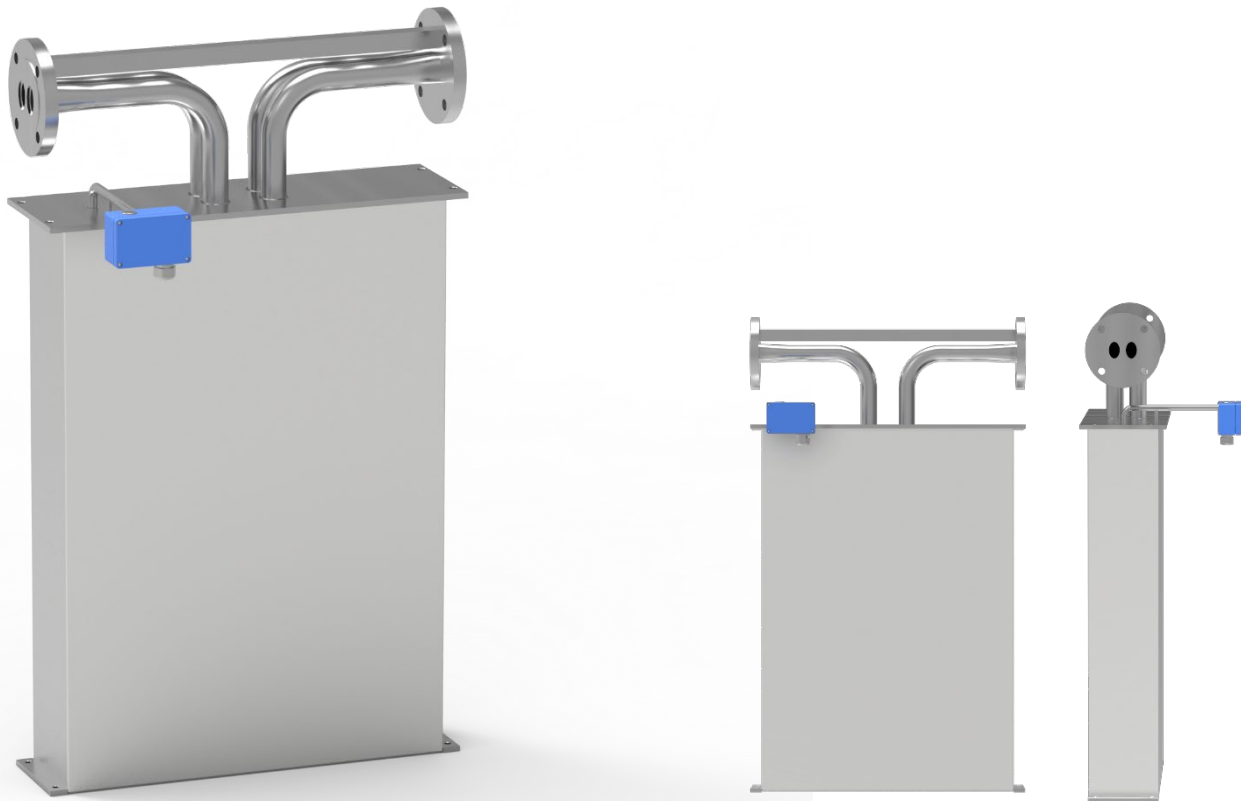



Features

- Typical measuring range up to 1500 kg/min (3306.93 lb/min)
- Pressure ratings up to 433 bar (6280 psi)
- Temperature ratings from -196 to +350 °C (-320 to +662 °F) – extended on request
- Mass flow uncertainty down to 0.1 %
- Repeatability down to 0.05 %
- 4 kHz measurement updates and response time of less than 10 ms when used with RHE 40 Series transmitters
- Accurately measure flow rates down to 20 kg/min
- The Rheonik **AnyPipeFit Commitment** provides custom process connection type and size flexibility on any meter to suit your existing plant, saving time and expense on installation costs
- Approved for use in hazardous areas
- SS 304 Stainless steel enclosure, SS 316 optional
- Integral and remote transmitter versions available

General Specification Overview

Nominal Flow (Q_{nom})*	1200 kg/min (2645.6 lb/min)
Maximum Flow (Q_{max})*	1500 kg/min (3306.9 lb/min)
Typical Minimum Flow (Q_{min})*	20 kg/min (44.1 lb/min)
Serial Tube / Single Path	Flow rates Q_{max} , Q_{nom} and Q_{min} for "serial" sensors will be 50% of the above listed parallel/dual path version.
Operating Temperature	Fluid temperature range options cover applications from -196°C to +350°C (-320°F to +662°F). For integral transmitter versions please refer to transmitter datasheet
Ambient Temperature	-50 °C to +80 °C (-60 °F to +180 °F) (standard)
Pressure Ratings	Up to 433 bar / 6280 psi - dependent upon material
Electrical Connection Sensor w/o Integral Transmitter	M20 x 1.5 standard cable entry for JM, SM terminal box versions Optional entries available : ½" NPT or M25 x 1.5 (only for SM) or ¾" NPT (only for SM) Max. cable length to remote RHE transmitter 100 m / 328 ft
Sensor Enclosure Materials	Stainless steel 304 (standard), SS 316 (optional) Coated aluminum terminal box, SS 316 terminal box (optional)
Enclosure Type	Protection class IP66, NEMA 4X (standard), IP66/67, NEMA 4X/6 (optional)
Wetted Materials	1.4571 (SS 316Ti), 1.4410 (SuperDuplex), 2.4602 (Alloy C22) - standard Tantalum - Consult Factory Additional/customer specific materials available upon request
Process Connections	Nearly any – the Rheonik AnyPipeFit Commitment . Consult factory for types/sizes not listed in this data sheet on the Mechanical Construction pages
Pressure Rating Compliance	Europe – PED: Module A2, Module B3.1+C2 Canada – CRN: Canadian Registration Number
Certifications and Approvals	ATEX / IECEx Approvals for Zone 0, 1, 2 (details see page 12) North American Approvals Class I, Div. 1, 2, Gr. A,B,C,D, Zone 0, 1, 2 MID custody transfer approval (OIML R117) American Bureau of Shipping (ABS) Product Type Approval for use on marine vessels
Testing and Inspection	All sensors are hydro tested, calibrated and supplied with a traceable calibration certificate. Customized calibration and testing services are available
Project Documentation and QA, Services	Rheonik offers a full set of services for large and complex engineering projects. Typical services offered are, but not limited to: <ul style="list-style-type: none"> • Certificates of origin and conformity, mill certificates • Data books including WPAR, WQS, NDT, test & quality plans, functional testing, calibration procedures, customized packing, factory acceptance etc. • Painting to project specification • Start up and commissioning services on/offshore
Options	Enclosure heating for high temperature applications Cleaning for oxygen service , ... For more consult factory

* At Q_{nom} pressure drop across a parallel tube sensor will be approximately 1 bar (15 psi) for H₂O. Sensors can be operated at higher flow rates up to Q_{max} but pressure drop will be higher. Typical Minimum Flow Q_{min} is the recommended lowest flow rate for an accurate measurement. Sensors will measure flow rates lower than Q_{min} but uncertainty will increase beyond 1% of rate.

The flow rate specifications above relate to standard pressure, parallel tube, manifold sensor versions. Models with higher pressure ratings have increased wall thickness and will have higher pressure drops.

Calibration Options

Standard and Premium Calibration

A	0.20 % Uncertainty <i>Requires RHE 20 Series transmitter. All others 0.5 %</i>
B	0.15 % Uncertainty <i>Requires RHE 20 Series transmitter or higher</i>

Premium Plus and Ultimate Calibration

G	0.10 % Uncertainty <i>Requires RHE 20 Series transmitter or higher</i>
----------	--

Low Flow and Customized Calibration

1	0.10 % Low Flow Focused Calibration* <i>Requires RHE 40 Series transmitter</i>
X	Customized Calibration** <i>Consult factory</i>

* Low flow calibration focuses on the range from $Q_{nom}/2$ downwards to lower flow rates than on other calibrations. Often used for low pressure gas or very viscous liquids
 ** Customized calibration uses specific calibration points according to customer requirements

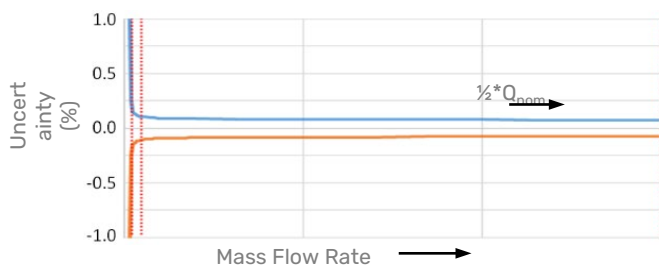

Uncertainties and flow measurement turn-down

The turn down capability from Q_{nom} of the flow sensor is driven mainly by its zero point stability. At the very low end of the measuring range the uncertainty (u) is dominated by the zero point stability. The zero stability of a standard sensor is: 0.15 kg/min (0.33 lbs/min). Zero point stability of a Gold Line sensor is 0.12 kg/min (0.27 lbs/min).

For flow $Q \geq ZP \text{ stability} / (\text{Base Calibration uncertainty}/100) \rightarrow u = \text{calibration uncertainty}$
 For flow $Q < ZP \text{ stability} / (\text{Base Calibration uncertainty}/100) \rightarrow u = (\text{zero stability}/Q) * 100$

Uncertainties from environmental and process conditions

- If sensors are not zeroed at operating conditions, minor additional uncertainties can arise from elevated temperatures and pressures: $\pm 0.000383 \%$ of maximum flow per $^{\circ}\text{C}$ and $\pm 0.000007 \%$ of maximum flow per bar.
- Process temperature effect on density: additional uncertainty of $\pm 0.000136 \text{ g/cm}^3$ per $^{\circ}\text{C}$ difference from calibration temperature with standard density calibration and of $\pm 0.000015 \text{ g/cm}^3$ per $^{\circ}\text{C}$ difference from calibration temperature with enhanced density calibration. This effect can be mitigated by a simple field density adjustment at operating conditions.
- Process pressure effect on mass flow: The effect of pressure on flow measurement is 0.001232 % of rate per bar. Compensation is possible by pressure sensor input (analog input or digital write) or manual value entry into the transmitter.
- Process pressure effect on density: The effect of pressure on density measurement is 0.0 g/cm³ per bar. Compensation is possible by pressure sensor input (analog input or digital write) or manual value entry into the transmitter.

Premium Plus, Low Flow and Enhanced Density Calibration come with Gold Line sensors and are not available in all materials, pressure and temperature ranges.

Reference conditions: 18–24 °C Water @ 1–3 bar; Gas (Natural gas) 35–100 bar.

Density Calibration / Performance (Liquid)

N	No Density Calibration
S	Standard $\pm 0.001 \text{ kg/liter}$ Uncertainty
D	Enhanced $\pm 0.0005 \text{ kg/liter}$ Uncertainty

Flow Measurement Repeatability

Standard Sensors $\pm 0.1 \%$ of rate
 Gold Line Sensors $\pm 0.05 \%$ of rate

Temperature Measurement

Better than $\pm 1^{\circ}\text{C}$

Pressure Drop

Every Coriolis flow sensor generates pressure drop across its inlet and outlet when in use. The amount of pressure drop generated is mainly a function of the flow velocity within its tubes and the flowing viscosity of the stream.

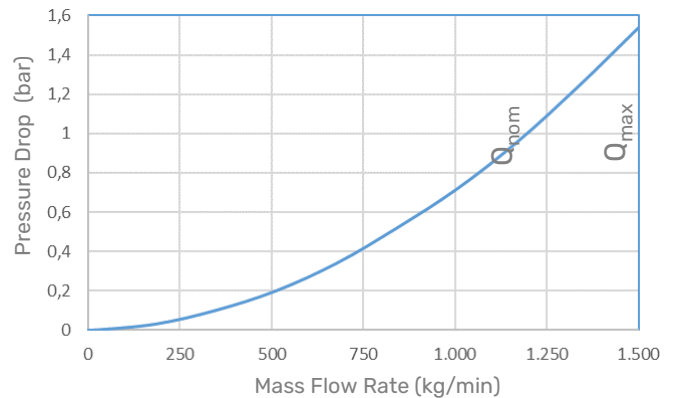

0 – 1500 kg/min water, sensor with P1 pressure rating. Higher viscosities create higher pressure drop

Measurement Tube Materials and Pressure Ratings

The maximum pressure (p_{max}) of a sensor is determined by its lowest rated part. The lowest rated part can be either the measurement tube (p_{max} see table to the right), the connection block/manifold (p_{max} indicated in the mechanical construction section) or the process connection (for p_{max} see published standards or manufacturer information).

Material	Pressure Code	50°C / 122°F	120°C / 248°F	210°C / 410°F	350°C / 662°F
SS 316Ti (standard)	P1	164 2379	147 2132	127 1842	107 1552
SuperDuplex*	P2	258 3742	242 3510	210 3046	n/a
SuperDuplex*	P3	433 6280	380 5511	343 4975	n/a

* Note minimum operating temperature for SuperDuplex stainless steel is -40 °C

Units: bar / psi

Other Materials

Other wetted materials may be possible for chemical compatibility, lower pressure drop, abrasion allowance, other application specific requirements. Rheonik can provide nearly any material for the wetted parts.
Contact factory with specification for assessment and availability.

Mechanical Construction

Sensors are manufactured with two internal measurement tubes arranged side by side. In parallel or dual path sensors (order code Pxx), these tubes are connected in parallel and the flowing fluid is split equally between them. In serial or single path sensors (order code Sxx), the internal tubes are connected end to end, creating a single path through which all fluid flows.

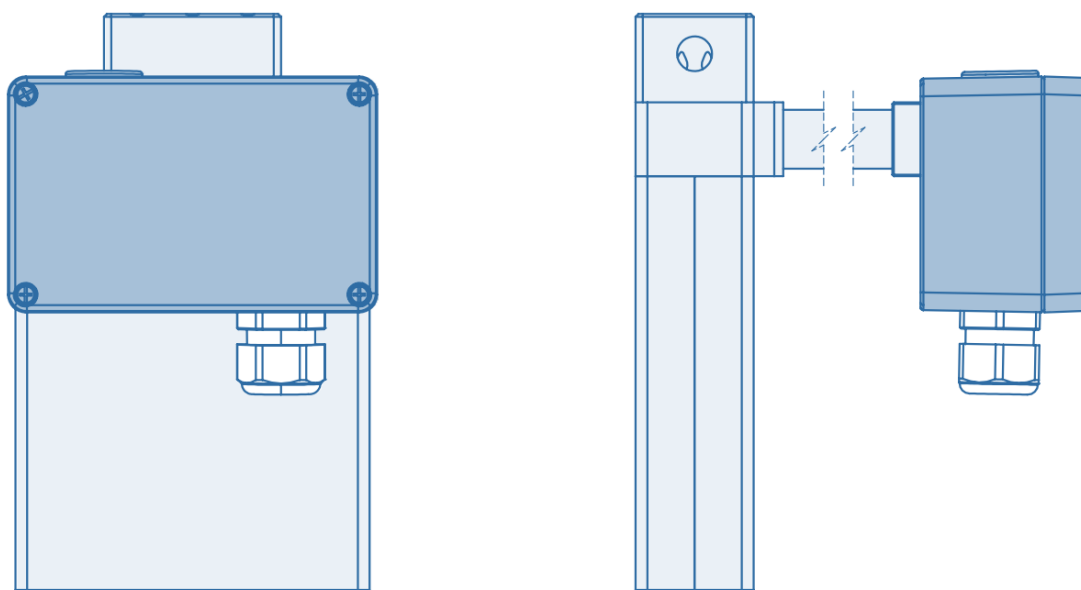

Note

All dimensions are for standard products. For customization of face to face length and/or process connection types other than the ones listed on this page, please consult factory. Note that larger diameter flange process connections are always possible.

Sealless design with flange connections

PFO: parallel / dual path

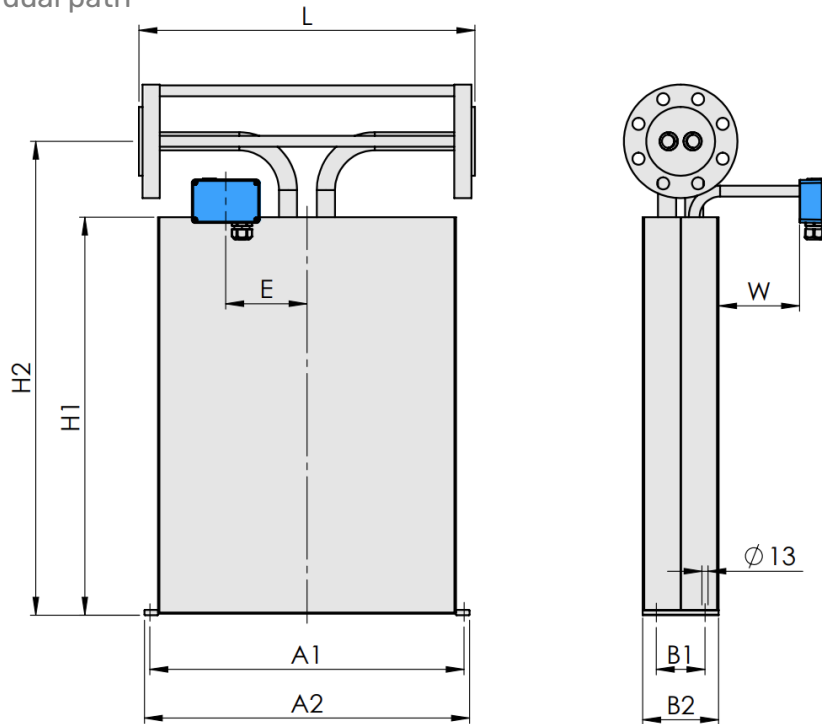

Process Connection PFO	Dim. L mm / in	Order Code
Flange ANSI 3" 150# RF/SF	725 / 28.54	A1
Flange ANSI 3" 300# RF/SF	725 / 28.54	A2
Flange ANSI 3" 600# RF/SF	725 / 28.54	A3
Flange ANSI 3" 900# RTJ	725 / 28.54	R6
Flange ANSI 3" 1500# RTJ	725 / 28.54	R1
Flange ANSI 3" 2500# RTJ	725 / 28.54	R2
Flange DIN DN80/PN40 Form B1	725 / 28.54	D1
Flange DIN DN80/PN100 Form B2	725 / 28.54	D2

PFO Dimensions	mm	in
A1	690	27.17
A2	720	28.35
B1	143	5.63
B2	180	7.09
H1	963	37.91
H2	1153	45.39
V	60	2.36
E	250	9.84
W	150	5.91

Weights and Shipping Dimensions

- Approx. weight with 3" 150# flanges: 140 kg / 309 lb
- Shipping in wooden crate as per ISPM 15, approx. 150 x 100 x 71 cm (60 x 40 x 28 in)
- Gross weight with 3" 150# flanges and RHE28 transmitter approx. 180 kg / 397 lb

Sealless design with flange connections

SFO: serial / single path

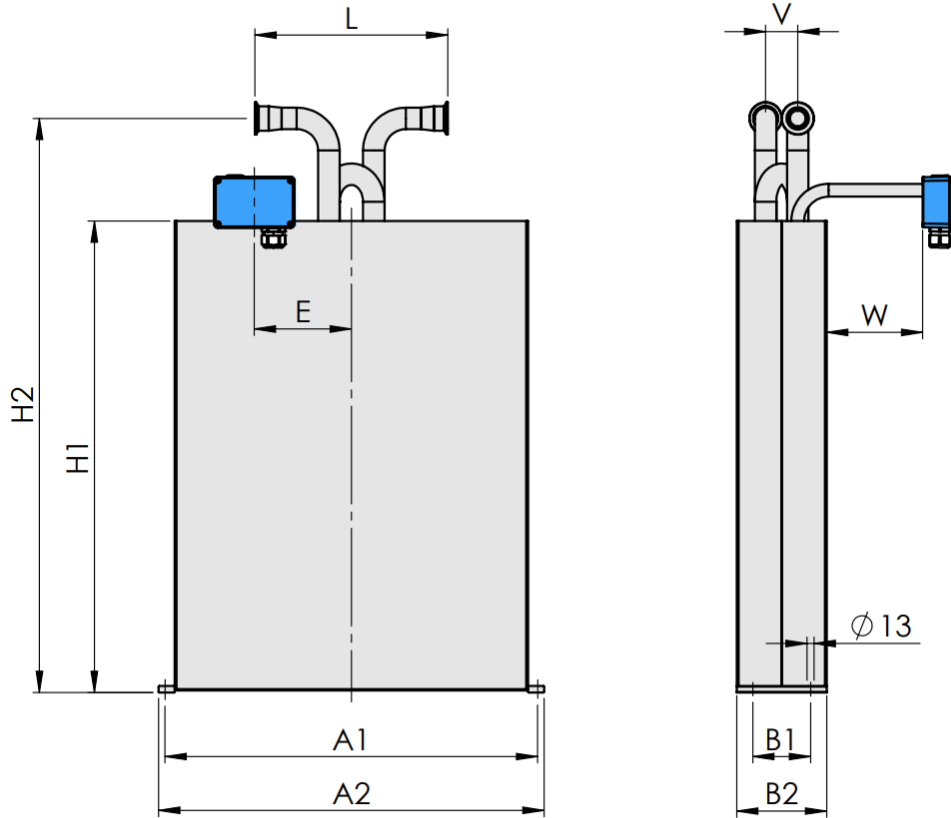

Process Connection SFO	Dim. L mm / in	Order Code
Sanitary 2" Triclamp, DIN 32676	400 / 11.81	S1
Sanitary NW50, DIN 11851	400 / 11.81	S2

SFO Dimensions	mm	in
A1	690	27.17
A2	720	28.35
B1	143	5.63
B2	180	7.09
H1	963	37.91
H2	1153	45.39
V	60	2.36
E	250	9.84
W	150	5.91

Transmitter Range

Any Rheonik Mass Flow Transmitter model can be combined with any Rheonik Mass Flow Sensor to provide an overall mass flow measurement system to suit any requirement. Rheonik Coriolis Transmitters are available in versions specifically designed for process, industrial and OEM applications. Economical blind front versions of some transmitters are available where displays and keypads are not required. The wide range of sensors and transmitters provide tremendous options for system designers and end users alike.

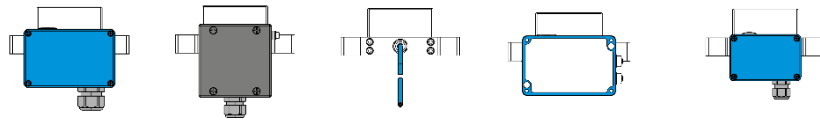

Product Code	JM	SM	TM	J5	PM
 RHE 21	✓	✓	✓	-	✓
 RHE 26	✓	✓	✓	-	✓
 RHE 27	✓	✓	✓	-	✓
 RHE 28	✓	✓	✓	-	✓
 RHE 42	✓	✓	✓	-	✓
 RHE 45	-	-	-	✓	-

RHM 40 Part Number Code

Temperature Range

- N1 -20 to +120°C (-4 to +248°F)
- NA -50 to +120°C (-58 to +248°F)
- E2 -50 to +210°C (-58 to +410°F)
- E3 -196 to +50°C (-320 to +122°F)
- H4 -20 to +350°C (-4 to +662°F)

Pressure Range of Measurement Loops @ 120°C / 248°F

See pressure ratings page for ratings and codes

Construction Type - p_{max} indications refer to 120°C / 248°F

- PFO Parallel tube, sealless - only with flange
- SFO Serial tube, sealless - only with sanitary connections and Material M1

Material of Measuring Loops

- M1 316Ti / EN 1.4571 / UNS S31635
- 10 SuperDuplex / EN 1.4410 / UNS S32750 - only for PFO
- M3 Alloy C22 / EN 2.4602 / UNS N06022. For PED please consult PED Advisor Sheet
- M4 Tantalum / (no EN) / UNS R05200 - only for Type P1-PFO. For PED please consult PED Advisor Sheet

Process Connection

See mechanical construction pages for available connections and codes

Electrical Connection to Transmitter

- JM Terminal Box coated Aluminum - M20 x 1.5 cable entry, see Accessories for others - not with Haz. Area A0
- J5 Alu Box ready for integrated RHE45 - temperature restrictions apply - only Haz. Area NN
- SM Terminal Box in SS316 - M20 x 1.5 cable entry, see Accessories for others
- TM Integral PTFE Cable to RHE, 2m - not with H4, A0. C0 only with N1, NA

Options Codes

See options listing for specific codes

Hazardous Area Certifications (details see page 12)

- NN Without Ex Approval
- A2 ATEX/IECEx Approvals Zone 2
- A1 ATEX/IECEx Approvals Zone 1 - requires suitably rated RHE
- A0 ATEX/IECEx Approvals Zone 0 - requires Elec. Conn. SM, suitably rated RHE
- C2 CSA Approval US-Canada Class I, Zone 2, Gas IIC - requires suitably rated RHE - not with Temp. H4
- C0 CSA Approval US-Canada Class I, Div. 1 / Zone 0, Gas IIC - requires suitably rated RHE

Pressure Design Compliance

- NN Rheonik standard design based on EN codes (no PED - not for sales into EU)
- A2 PED compliance according to module A2 - required if flow does not represent an unstable gas
- BC PED compliance according to module B3.1 + C2 - required if A2 does not apply
- CA CRN compliance - Alberta Province Only
- CR CRN compliance - All Provinces except Alberta

Performance Certification

- NN No Performance Certification
- AB ABS approval for marine applications - includes approval for RHE Transmitter
- R7 MID MI-005 approval for liquids OIML R117 - requires RHE4x

Mass Flow, Density Calibration Selection

See performance page for code options

Manufacturing Instruction Codes

See instructions listing for specific codes (next page)

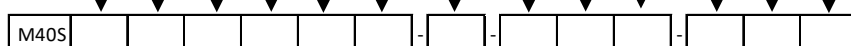

Options and Manufacturing Instruction Codes

Options Codes	
NN	Without Option
H1	Heating for Housing, Steam - Connection DN25 PN40
H2	Heating for Housing, Steam - Connection 1" ANSI 150 RF
H3	Heating for Housing, Steam - Connection 1" ANSI 300 RF
SB	Housing and base plate in SS 316 - check with factory for lead time
T1	Terminal box with cable entry upwards/gas installation
P2	Housing purge NPT ½" (2 pcs)

NOTE: when specifying a sensor with multiple part code options (i.e. P2 and SB), separate each code with a comma in the part string (i.e. ...P2,SB...)

Instructions	
N	No manufacturing instructions
7	Upgrade to dual rating IP66/67 - only with electrical connection SM
O	Special Cleaning, fat free
S	Sea-worthy packing

Additional separate choices

Options	Order Code ORHM-...
E1	Terminal box prepared for ½" NPT cable entry
E2	Terminal box prepared for M25 x 1.5 cable entry - only with electrical connection SM
E3	Terminal box prepared for ¾" NPT cable entry - only with electrical connection SM
TP	Separate TAG Plate in Stainless Steel (TAG Information only)
TP-C	Type Label in Stainless Steel (TAG and all other label information)

Standard cable entry on JM, SM terminal box is M20 x 1.5. Cable entry on PM terminal box is always M16 x 1.5

Hazardous Area Certifications

Code	Zone / Division	Approval	Labeling
A0	Zone 0	ATEX	II 1G Ex ia IIC T6...T1 Ga
A1	Zone 1	ATEX	II 2G Ex ib IIC T6...T1 Gb
AB	Zone 0	ATEX	II 1G Ex ia IIB T6...T1 Ga
AB	Zone 1	ATEX	II 2G Ex ib IIB T6...T1 Gb
A2	Zone 2	ATEX	II 3G Ex ec IIC T6...T1 Gc
A0	Zone 0	IECEX	Ex ia IIC T6...T1 Ga
A1	Zone 1	IECEX	Ex ib IIC T6...T1 Gb
A2	Zone 2	IECEX	Ex ec IIC T6...T1 Gc
C0	Div 1, Zone 0	Zone USA/Kanada	Class I, Div 1, Groups A, B, C and D T6...T1; Class I, Zone 0, AEx ia IIC T6...T1 Ga
CB	Div 1, Zone 0	Zone USA/Kanada	Class I, Div 1, Groups C and D T6...T1; Class I, Zone 0, AEx ia IIB T6...T1 Ga
C2	Zone 2	Zone USA/Kanada	Class I, Zone 2, AEx nA IIC T6...T1 Gc





About Rheonik

Rheonik has but one single purpose: to design and manufacture the very best Coriolis meters available.

Our research and engineering resources are dedicated to finding new and better ways to provide cost effective accurate mass flow solutions that provide value to our customers. Our manufacturing group care for each and every meter we produce from raw materials all the way to shipping, and our service and support group are available to help you specify, integrate, start-up and maintain every Rheonik meter you have in service. Whether you own just one meter or have hundreds, you will never be just another customer to us. You are our valued business partner.

Need a specific configuration for your plant? Don't compromise with a "standard" product from elsewhere that will add extra cost to your installation. If we can't configure it from our extensive and versatile product range, our exclusive **AnyPipeFit Commitment** can have your flow sensor customized with any size/type of process connection and face to face dimension you need.

No matter what control system you use as the backbone in your enterprise, with our **AnyInterface Commitment**, you can be sure that connection and communication will not be a problem. Alongside a wide variety of discrete analog and digital signal connections, we can also provide just about any network/bus interface available (for example: HART, ProfibusDP, ProfiNet, EtherCAT, PowerLink, EtherNet/IP, CAN,) with our RHE 40 Series family of transmitters. Rheonik RHE 40 Series transmitters can connect to your system – no headache and no conversion needed.

Rheonik Messtechnik GmbH
Rudolf-Diesel-Straße 5
D-85235 Odelzhausen
Germany

Tel + 49 (0)8134 9341-0
Info@rheonik.com

