



RHM 04

Coriolis Mass Flow Meter for Batching/Filling and Accurate Measurement

General Flow Control / Additive Dosing / Mixing and Batching /
Chemical Injection / Package and Container Filling





Features

- Typical measuring range up to 18 kg/min (39.68 lb/min)
- Pressure ratings up to 1401 bar (20319.79 psi)
- Temperature ratings from -196 to +210 °C (-320 to +410 °F) – extended on request
- Mass flow uncertainty down to 0.05 %
- Repeatability down to 0.05 %
- 4 kHz measurement updates and response time of less than 10 ms when used with RHE 40 Series transmitters
- Accurately measure flow rates down to 50 g/min
- The Rheonik **AnyPipeFit Commitment** provides custom process connection type and size flexibility on any meter to suit your existing plant, saving time and expense on installation costs
- Compact design with minimal pipeline footprint
- Approved for use in hazardous areas
- SS 304 Stainless steel enclosure, SS 316 optional
- Integral and remote transmitter versions available

General Specification Overview

Nominal Flow (Q_{nom})*	12 kg/min (26.46 lb/min)
Maximum Flow (Q_{max})*	18 kg/min (39.68 lb/min)
Typical Minimum Flow (Q_{min})*	0.06 kg/min (0.13 lb/min)
Serial Tube / Single Path	Flow rates Q_{max} , Q_{nom} and Q_{min} for "serial" sensors will be 50% of the above listed parallel/dual path version.
Operating Temperature	Fluid temperature range options cover from -196 °C to +210 °C (-320 °F to +410 °F) For integral transmitter versions please refer to transmitter datasheet
Ambient Temperature	-50 °C to +80 °C (-60 °F to +180 °F). High temperature version for oven installation up to +210 °C (+410 °F) available
Pressure Ratings	Up to 1401 bar / 20319.79 psi – dependent upon material
Electrical Connection Sensor w/o Integral Transmitter	M20 x 1.5 standard cable entry for JM, SM terminal box versions Optional entries available : ½" NPT or M25 x 1.5 (only for SM) or ¾" NPT (only for SM) M16 x 1.5 standard cable entry for PM terminal box version Max. cable length to remote RHE transmitter 100 m/330 ft.
Sensor Enclosure Materials	Stainless steel 304 (standard), SS 316 (optional) Coated aluminum terminal box, SS 316 terminal box (optional)
Enclosure Type	Protection class IP 66, NEMA 4 (standard), IP 66/67, NEMA 4X (optional)
Wetted Materials	Flow tubes SS 316L, Sandvik HP160 or SuperDuplex Manifolds SS 316L, seals FKM, FFKM, FVMQ Standard flanges SS 316Ti, other connections SS 316L Additional/customer specific materials available upon request
Process Connections	Nearly any – the Rheonik AnyPipeFit Commitment . Consult factory for types/sizes not listed in this data sheet on the Mechanical Construction pages
Pressure Rating Compliance	PED 2014/68/EU Article 4, Section 3 (SEP)
Certifications and Approvals	ATEX / IECEx Approvals Zone 0, 1, 2 (see page 19) North American Approvals Cl. I, Div. 1, 2, Gr. A, B, C, D, Zone 0, 1, 2 OIML, MID custody transfer approval American Bureau of Shipping (ABS) Product Type Approval for use on marine vessels
Testing and Inspection	All sensors are hydro tested, calibrated and supplied with a traceable calibration certificate. Customized calibration and testing services are available
Project Documentation and QA, Services	Rheonik offers a full set of services for large and complex engineering projects. Typical services offered are, but not limited to: <ul style="list-style-type: none"> • Certificates of origin and conformity, mill certificates • Data books including WPAR, WQS, NDT, test & quality plans, functional testing, calibration procedures, customized packing, factory acceptance etc. • Painting to project specification • Start up and commissioning services on/offshore
Options	Customization services for machine integration. Consult factory

* At Q_{nom} pressure drop across a parallel tube sensor will be approximately 1.6 bar (23.2 psi) for H2O. Sensors can be operated at higher flow rates up to Q_{max} but pressure drop will be higher. Typical Minimum Flow Q_{min} is the recommended lowest flow rate for an accurate measurement. Sensors will measure flow rates lower than Q_{min} but uncertainty will increase beyond 1 % of rate.

The flow rate specifications above relate to standard pressure, parallel tube, manifold sensor versions. Models with higher pressure ratings have increased wall thickness and will have higher pressure drops.

Calibration Options

Standard and Premium Calibration

A	0.20 % Uncertainty <i>Requires RHE 20 Series transmitter or higher</i>
B	0.15 % Uncertainty <i>Requires RHE 20 Series transmitter or higher</i>

Premium Plus and Ultimate Calibration

G	0.10 % Uncertainty <i>Requires RHE 20 Series transmitter or higher</i>
U	0.05 % Uncertainty <i>Requires RHE 40 Series transmitter</i>

Low Flow and Customized Calibration

1	0.10 % Low Flow Focused Calibration* <i>Requires RHE 40 Series transmitter</i>
X	Customized Calibration** <i>Consult factory</i>

* Low flow calibration focuses on the range from $Q_{nom}/2$ downwards to lower flow rates than on other calibrations. Often used for low pressure gas or very viscous liquids
 ** Customized calibration uses specific calibration points according to customer requirements

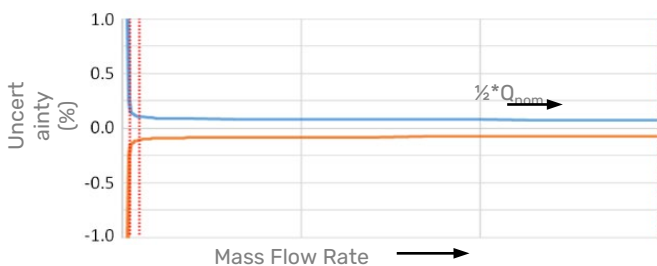

Uncertainties and flow measurement turn-down

The turn down capability from Q_{nom} of the flow sensor is driven mainly by its zero point stability. At the very low end of the measuring range the uncertainty (u) is dominated by zero point stability. The zero point stability of a standard sensor is: 0.0006 kg/min (0.00132 lbs/min). Zero point stability of a Gold Line sensor is 0.0004 kg/min (0.000882 lbs/min).

For flow $Q \geq ZP \text{ stability} / (\text{Base Calibration uncertainty}/100) \rightarrow u = \text{calibration uncertainty}$
 For flow $Q < ZP \text{ stability} / (\text{Base Calibration uncertainty}/100) \rightarrow u = (\text{zero stability}/Q) * 100$

Uncertainties from environmental and process conditions

- If sensors are not zeroed at operating conditions, minor additional uncertainties can arise from elevated temperatures and pressures: $\pm 0.001\%$ of maximum flow per $^{\circ}\text{C}$ and $\pm 0.00011\%$ of maximum flow per bar.
- Process temperature effect on density: additional uncertainty of $\pm 0.000061 \text{ g/cm}^3$ per $^{\circ}\text{C}$ difference from calibration temperature with standard density calibration and of $\pm 0.000011 \text{ g/cm}^3$ per $^{\circ}\text{C}$ difference from calibration temperature with enhanced density calibration. This effect can be mitigated by a simple field density adjustment at operating conditions.
- Process pressure effect on mass flow: The effect of pressure on flow measurement is 0.001% of rate per bar. Compensation is possible by pressure sensor input (analog input or digital write) or manual value entry into the transmitter.
- Process pressure effect on density: The effect of pressure on density measurement is 0.00002 g/cm^3 per bar. Compensation is possible by pressure sensor input (analog input or digital write) or manual value entry into the transmitter.

Premium Plus, Ultimate, Low Flow and Enhanced Density Calibration come with Gold Line sensors and are not available in all materials, pressure and temperature ranges.

Reference conditions: 18–24 °C Water @ 1–3 bar; Gas (Natural gas) 35–100 bar.

Density Calibration / Performance (Liquid)

N	No Live Density Calibration
S	Standard $\pm 0.001 \text{ kg/liter}$ Uncertainty
D	Enhanced $\pm 0.0005 \text{ kg/liter}$ Uncertainty

Flow Measurement Repeatability

Standard Sensors $\pm 0.1\%$ of rate
 Gold Line Sensors $\pm 0.05\%$ of rate

Temperature Measurement

Better than $\pm 1^{\circ}\text{C}$

Pressure Drop

Every Coriolis flow sensor generates pressure drop across its inlet and outlet when in use. The amount of pressure drop generated is mainly a function of the flow velocity within its tubes and the flowing viscosity of the stream.

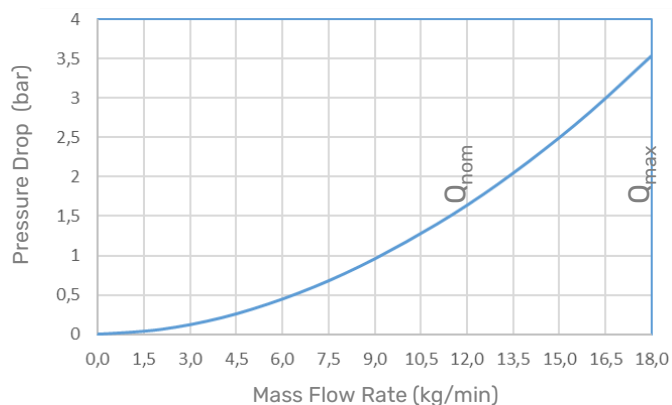

0 – 18 kg/min water, sensor with P1 pressure rating. Higher viscosities create higher pressure drop

Measurement Tube Materials and Pressure Ratings

The maximum pressure (p_{max}) of a sensor is determined by its lowest rated part. The lowest rated part can be either the measurement tube (p_{max} see table to the right), the connection block/manifold (p_{max} indicated in the mechanical construction section) or the process connection (for p_{max} see published standards or manufacturer information).

Material	Pressure Code	50°C / 122°F	120°C / 248°F	210°C / 410°F
SS 316L (standard)	P1	177 2567	157 2277	132 1915
SuperDuplex*	P2	712 10327	662 9602	594 8615
SuperDuplex*	P3	1087 15766	1048 15200	709 10283
SuperDuplex*	P4	1401 20320	1304 18913	1170 16969
Sandvik HP160	P2	600 8702	540 7832	490 7106
Sandvik HP160	P3	1087 15766	1048 15200	709 10283

* Note minimum operating temperature for SuperDuplex stainless steel is -40 °C Units: bar / psi

Other Materials

Other wetted materials may be possible for chemical compatibility, lower pressure drop, abrasion allowance, other application specific requirements. Rheonik can provide nearly any material for the wetted parts.
Contact factory with specification for assessment and availability.

Mechanical Construction

Sensors are manufactured with two internal measurement tubes arranged side by side. In parallel or dual path sensors (order code Pxx), these tubes are connected in parallel and the flowing fluid is split equally between them. In serial or single path sensors (order code Sxx), the internal tubes are connected end to end, creating a single path through which all fluid flows. Manifold designs have a removable inlet/outlet manifold block and utilize selectable seals between the manifold and sensor body. In sealless designs, the measurement tubes are continuous between the process connections and do not have seals. Manifold designs offer shorter delivery lead times and may have a lower pressure drop than sealless designs for the same flow rate.

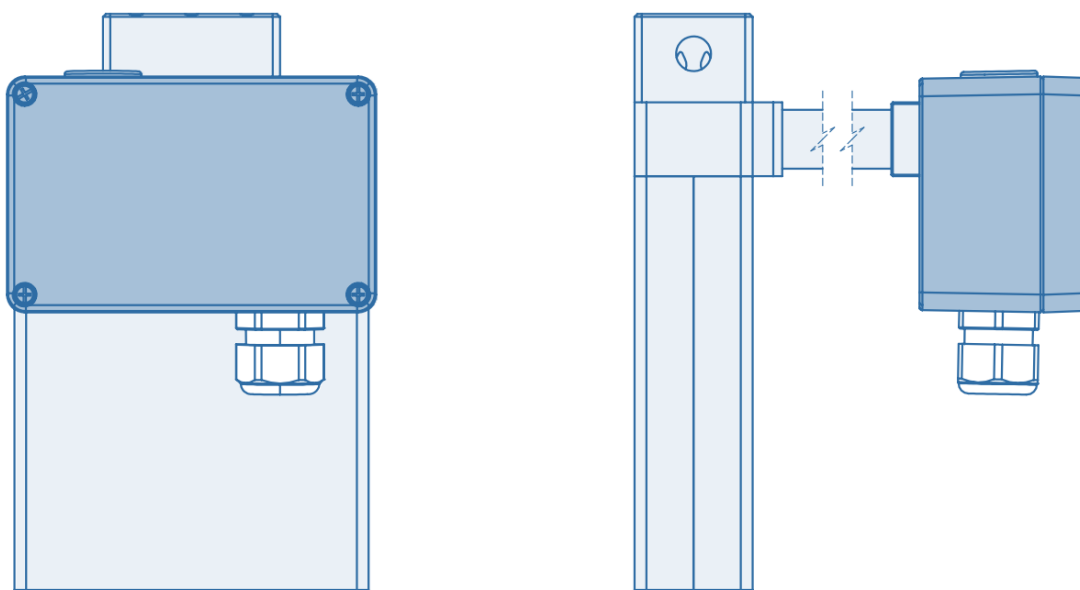

Note

All dimensions are for standard products. For customization of face to face length and/or process connection types other than the ones listed on this page, please consult factory. Note that larger diameter flange process connections are always possible.

Manifold design with thread connections

PM0/PH0: parallel tube / dual path

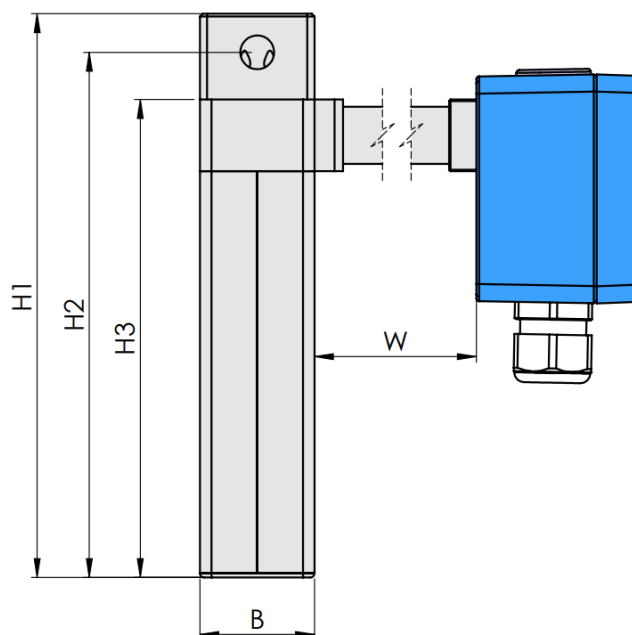
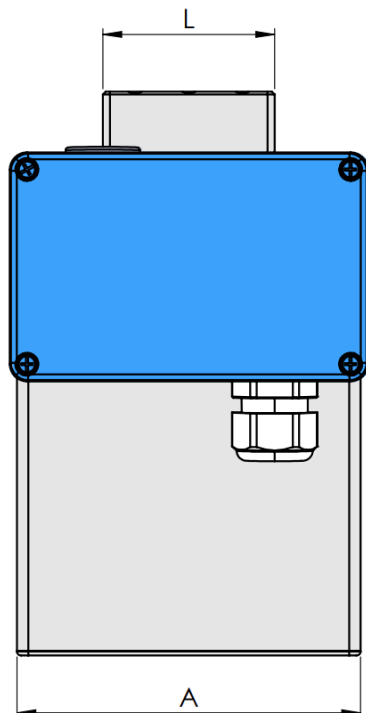

Process Connection PM0 / PH0	Dim. L mm / in	Order Code
Female Thread G ¼" (only PM0)	60 / 2.36	G1
Female Thread ¼" NPT (only PM0)	60 / 2.36	N1
Autoclave ⅜" MP - ⅝" - 18 UNF Female Thread (only PH0)	70 / 2.76	P1

PM0 / PH0 Dimensions	mm	in
A	120	4.72
B	40	1.57
H1 (PM0, PH0)	222	8.74
H2	208	8.19
H3	192	7.56
W	see page 14	

Manifold Pressure Ratings @ 120 °C / 248 °F

PM0 – 700 bar / 10150 psi
 PH0 – 1220 bar / 17695 psi
 (20000 psi @ 50 °C / 122 °F)

Weights and Shipping Dimensions

- Weight for sensor with threads: ~3.5 kg/7.7 lb
- Shipping carton size ~60 x 41 x 32 cm (24 x 16 x 13 in)
- Gross weight with RHE 28, packaging ~9.5 kg/20.9 lb

Material of Manifold Seals (Wetted Part)

Depending upon sensor temperature range, sensors are supplied with the following seal types as standard. For alternative seal options (e.g. FFKM seals for N1) please see Options. Other seals on request.

Temperature Range	PM0	SM0	PH0	SH0
N1	FKM	FKM	FKM	FKM
NA	FVMQ	FVMQ	FVMQ	FVMQ
E2*	FFKM	FFKM	n/a	n/a

*FFKM seals minimum temperature is -20 °C/-4 °F; p_{max} = 700 bar

Manifold design with thread connections

SM0/SH0: serial tube / single path

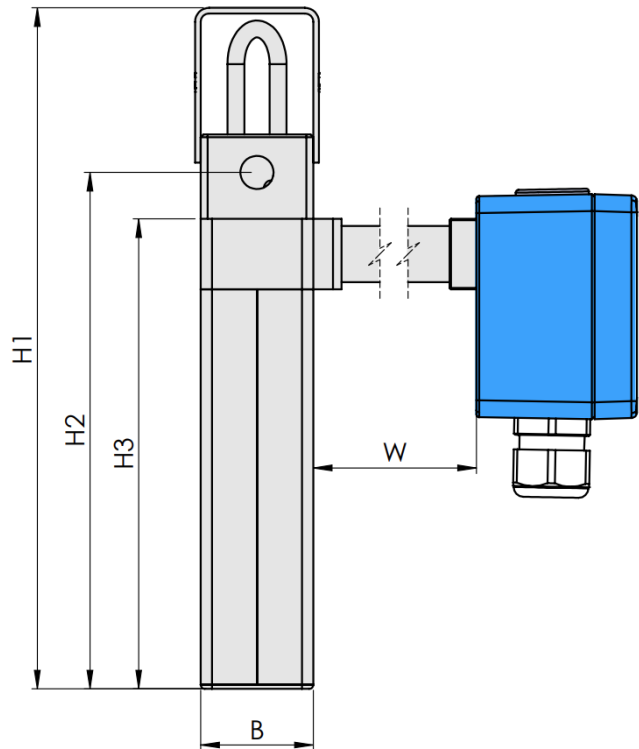
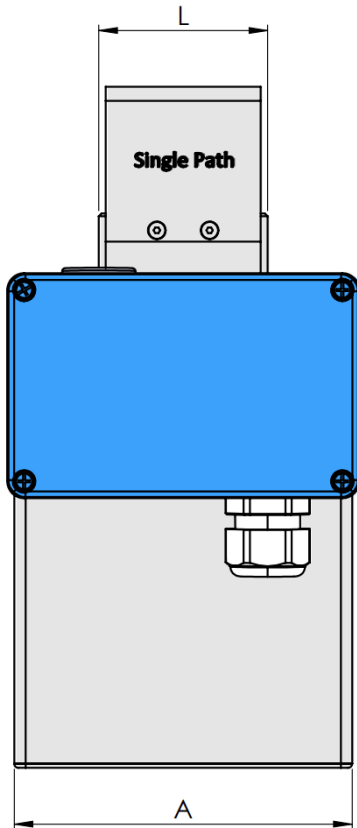

Process Connection SM0 / SH0	Dim. L mm / in	Order Code
Female Thread G 1/4" (only SM0)	60 / 2.36	G1
Female Thread 1/4" NPT (only SM0)	60 / 2.36	N1
Autoclave 3/8" MP - 3/16" - 18 UNF Female Thread (only SH0)	70 / 2.76	P1

Manifold Pressure Ratings @ 120 °C / 248 °F

SM0 – 700 bar / 10150 psi
 SH0 – 1220 bar / 17695 psi
 (20000 psi @ 50 °C / 122 °F)

SM0 / SH0 Dimensions	mm	in
A	120	4.72
B	40	1.57
H1 (SM0, SH0)	267	10.51
H2	208	8.19
H3	192	7.56
W	see page 14	

Weights and Shipping Dimensions

- Weight for sensor with threads: ~3.5 kg/7.7 lb
- Shipping carton size ~60 x 41 x 32 cm (24 x 16 x 13 in)
- Gross weight with RHE 28, packaging ~9.5 kg/20.9 lb

Material of Manifold Seals (Wetted Part)

Depending upon sensor temperature range, sensors are supplied with the following seal types as standard. For alternative seal options (e.g. FFKM seals for N1) please see Options. Other seals on request.

Temperature Range	PMO	SM0	PHO	SHO
N1	FKM	FKM	FKM	FKM
NA	FVMQ	FVMQ	FVMQ	FVMQ
E2*	FFKM	FFKM	n/a	n/a

*FFKM seals minimum temperature is -20 °C/-4 °F; pmax = 700 bar

Manifold design with flange connections

PMO: parallel tube / dual path

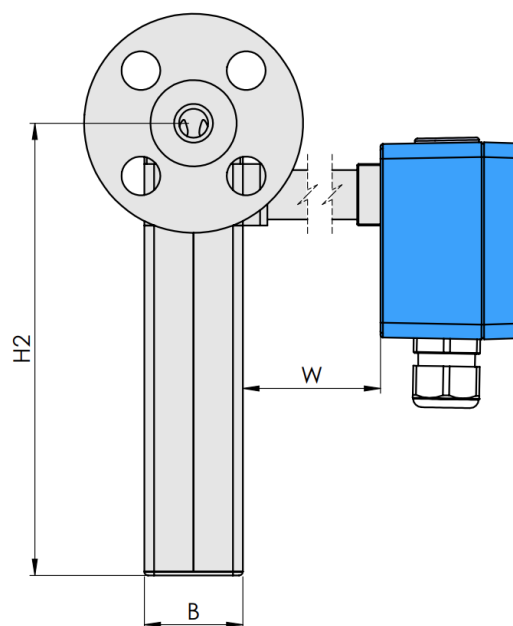
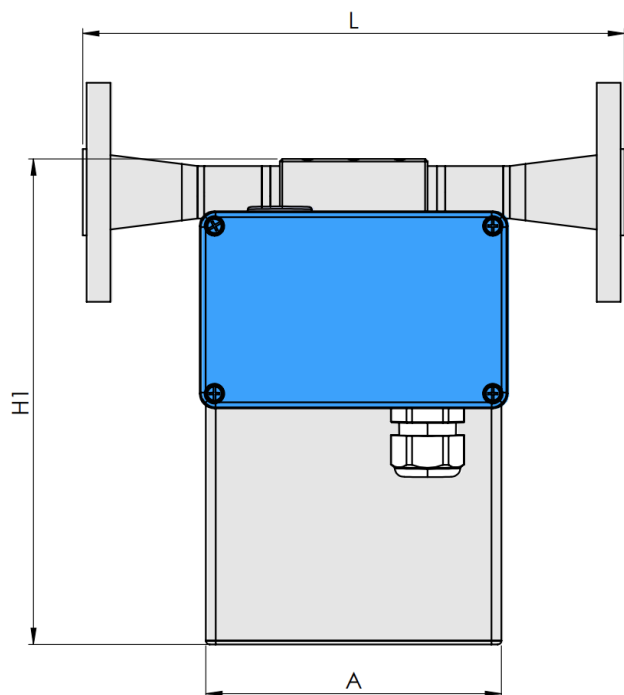

Process Connection PMO	Dim. L mm / in	Order Code
Flange ANSI ½" 150#RF	220 / 8.66	A1
Flange ANSI ½" 300#RF	220 / 8.66	A2
Flange ANSI ½" 600#RF	220 / 8.66	A3
Flange ANSI ½" 1500#RF	300 / 11.81	A4
Flange ANSI ½" 1500#RTJ	300 / 11.81	R1
Flange DIN DN15/PN40	220 / 8.66	D1
Flange DIN DN15/PN100	220 / 8.66	D2
Flange DIN DN15/PN160	220 / 8.66	D3
Flange JIS B 2220 RF 10k 15A	220 / 8.66	J1
Flange JIS B 2220 RF 20k 15A	220 / 8.66	J2

PMO Dimensions	mm	in
A	120	4.72
B	40	1.57
H1 (PMO)	222	8.74
H2	208	8.19
H3	192	7.87
W	see page 14	

Weights and Shipping Dimensions

- Weight for sensor with ½" 150# flanges: ~4.5 kg/9.9 lb
- Shipping carton size ~60 x 41 x 32 cm (24 x 16 x 13 in)
- Gross weight with RHE 28, packaging ~10.5 kg/23.1 lb

Material of Manifold Seals (Wetted Part)

Depending upon sensor temperature range, sensors are supplied with the following seal types as standard. For alternative seal options (e.g. FFKM seals for N1) please see Options. Other seals on request.

Temperature Range	PMO
N1	FKM
NA	FVMQ
E2	FFKM*

*FFKM seals minimum temperature is -20 °C/-4 °F

Manifold design with flange connections

SMO: serial tube / single path

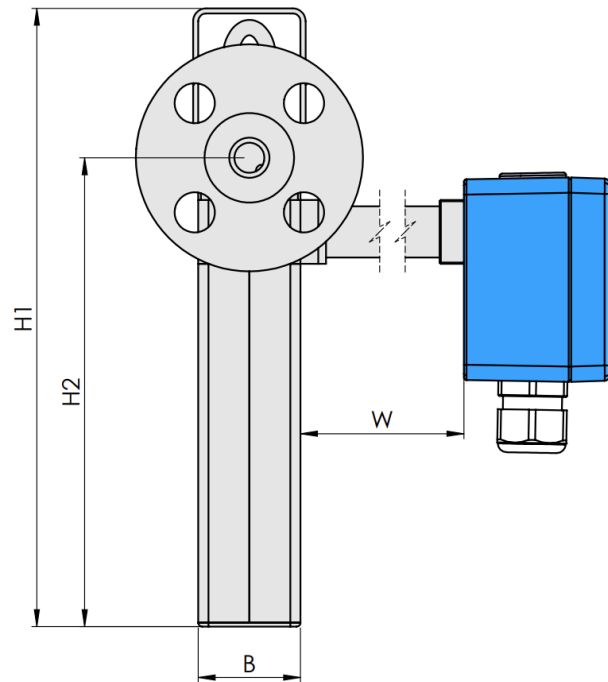
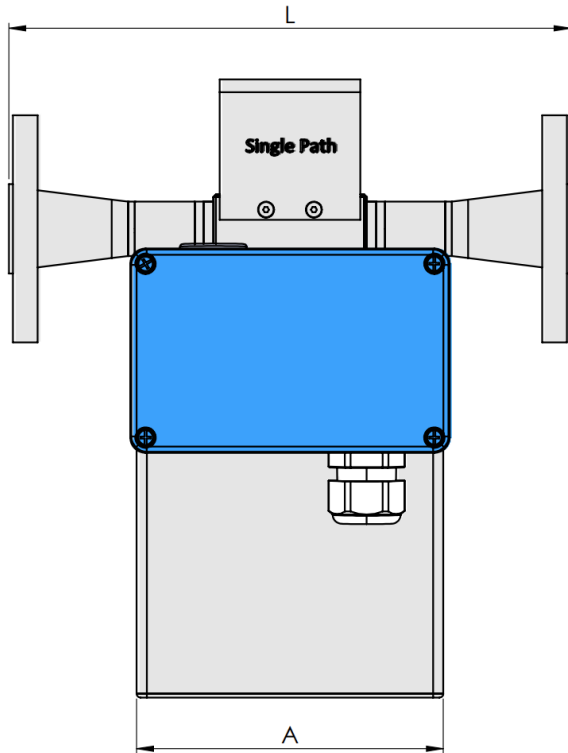

Process Connection SMO	Dim. L mm / in	Order Code
Flange ANSI ½" 150#RF	220 / 8.66	A1
Flange ANSI ½" 300#RF	220 / 8.66	A2
Flange ANSI ½" 600#RF	220 / 8.66	A3
Flange ANSI ½" 1500#RF	300 / 11.81	A4
Flange ANSI ½" 1500#RTJ	300 / 11.81	R1
Flange DIN DN15/PN40	220 / 8.66	D1
Flange DIN DN15/PN100	220 / 8.66	D2
Flange DIN DN15/PN160	220 / 8.66	D3
Flange JIS B 2220 RF 10k 15A	220 / 8.66	J1
Flange JIS B 2220 RF 20k 15A	220 / 8.66	J2

SMO Dimensions	mm	in
A	120	4.72
B	40	1.57
H1 (SMO)	267	10.51
H2	208	8.19
H3	192	7.56
W	see page 14	

Weights and Shipping Dimensions

- Weight for sensor with ½" 150# flanges: ~4.5 kg/9.9 lb
- Shipping carton size ~60 x 41 x 32 cm (24 x 16 x 13 in)
- Gross weight with RHE 28, packaging ~10.5 kg/23.1 lb

Material of Manifold Seals (Wetted Part)

Depending upon sensor temperature range, sensors are supplied with the following seal types as standard. For alternative seal options (e.g. FFKM seals for N1) please see Options. Other seals on request.

Temperature Range	SMO
N1	FKM
NA	FVMQ
E2	FFKM*

*FFKM seals minimum temperature is -20 °C/-4 °F

Sealless design with flange connections

PFO: parallel / dual path

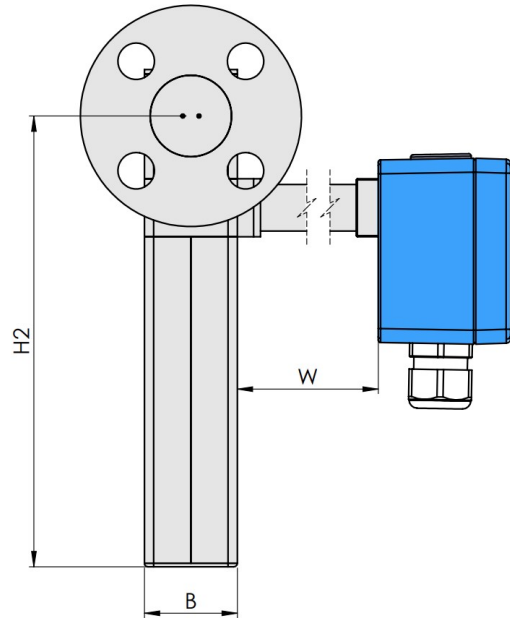
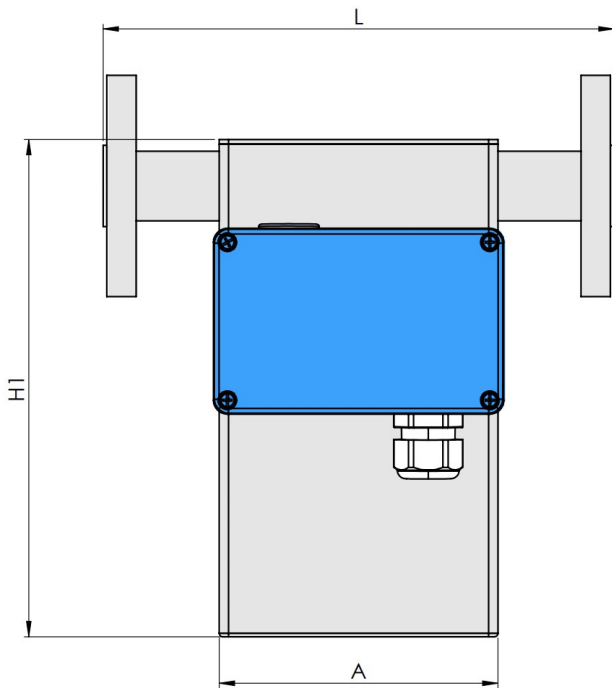

PFO Process Connection	Dim. L mm / in	Order Code
Flange ANSI ½" 150#RF	236 / 9.29	A1
Flange ANSI ½" 300#RF	236 / 9.29	A2
Flange ANSI ½" 600#RF	236 / 9.29	A3
Flange ANSI ½" 1500#RF	316 / 12.44	A4
Flange ANSI ½" 2500#RF	316 / 12.44	A5
Flange ANSI ½" 1500#RTJ	316 / 12.44	R1
Flange ANSI ½" 2500#RTJ	316 / 12.44	R2
Flange DIN DN15/PN40 Form B1	236 / 9.29	D1
Flange DIN DN15/PN100 Form B2	236 / 9.29	D2
Flange DIN DN15/PN160 Form B2	236 / 9.29	D3
Flange JIS B 2220 RF 10k 15A	236 / 9.29	J1
Flange JIS B 2220 RF 20k 15A	236 / 9.29	J2
Grayloc® Hub 1" GR4	316 / 12.44	H1

PFO Dimensions	mm	in
A	136	5.35
B	40	1.57
H1	247	9.72
H2	227	8.94
H3	200	7.87
W	see page 14	

For other hub connections (e.g. Destec, Galperti, Techlok) please consult factory

Weights and Shipping Dimensions

- Weight for sensor with ½" 150# flanges: 4 kg/8.8 lb
- Shipping carton size ~60 x 41 x 32 cm (24 x 16 x 13 in)
- Gross weight with RHE 28, packaging ~10 kg/22 lb

Sealless design with threaded connections

PFT: parallel / dual path

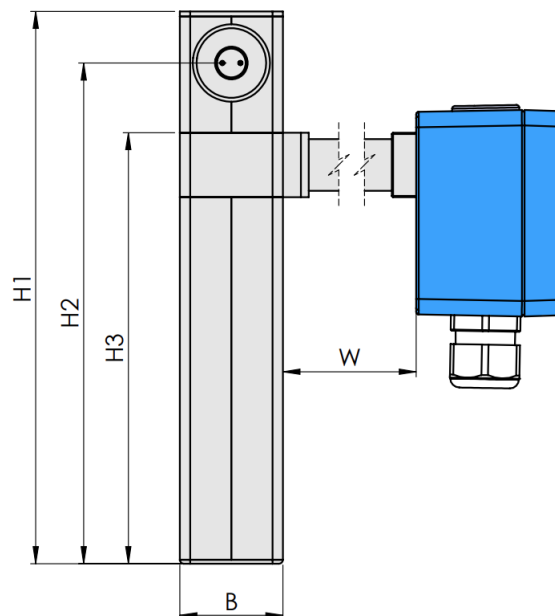
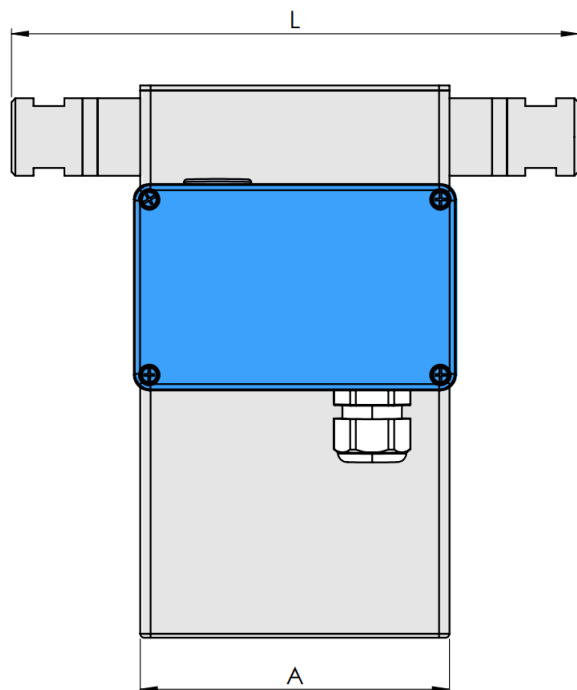

Process Connection PFT	Dim. L mm / in	Order Code
Female Thread G 1/4"	236 / 9.29	G1
Female Thread 1/4" NPT	236 / 9.29	N1
Autoclave 3/8" MP - 9/16" - 18 UNF Female Thread	236 / 9.29	P1
Swagelok® 1/4" Tube Inlet male (SS-400-1-4W)	236 / 9.29	W1
Swagelok® 1/4" O-Ring Connection male (SS-4-VCO-1)	Consult Factory	V1
Swagelok® 1/4" O-Ring Connection female (SS-4-VCO-3 and -4)	Consult Factory	V2
Swagelok® 1/4" with Metal Gasket female (SS-4-VCR-1 and -3)	Consult Factory	V3

PFT Dimensions	mm	in
A	136	5.35
B	40	1.57
H1	247	9.72
H2	227	8.94
H3	200	7.87
W	see page 14	

Weights and Shipping Dimensions

- Weight for sensor with threads: ~3 kg/6.6 lb
- Shipping carton size ~60 x 41 x 32 cm (24 x 16 x 13 in)
- Gross weight with RHE 28, packaging ~9 kg/19.8 lb

Sealless design with threaded connections

PMT: parallel / dual path

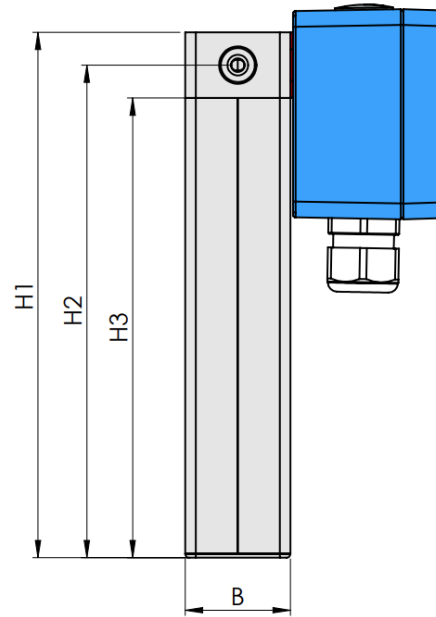
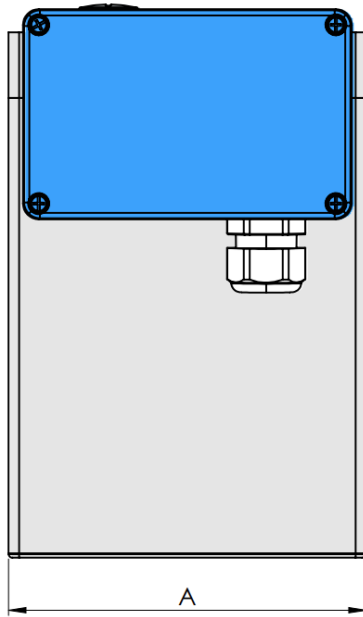

Process Connection PMT	Dim. A mm / in	Order Code
Autoclave 3/8" MP - 9/16" - 18 UNF female thread	136 / 4.72	P1

PMT Common Dimensions	mm	in
A	136	5.35
B	40	1.57
H1 (PMT)	200	7.87
H2 (PMT)	188	7.40
H3 (PMT)	175	6.89

Weights and Shipping Dimensions

- Weight for sensor with threads: ~3 kg/6.6 lb
- Shipping carton size ~60 x 41 x 32 cm (24 x 16 x 13 in)
- Gross weight with RHE 28, packaging ~9 kg/19.8 lb

Electrical Connection Options for remote RHE20, RHE40 Transmitters

JM Standard Terminal Box Coated Aluminum

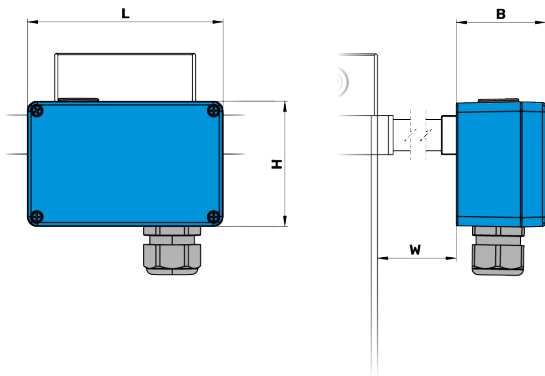

PM Extra Compact Terminal Box Coated Aluminum

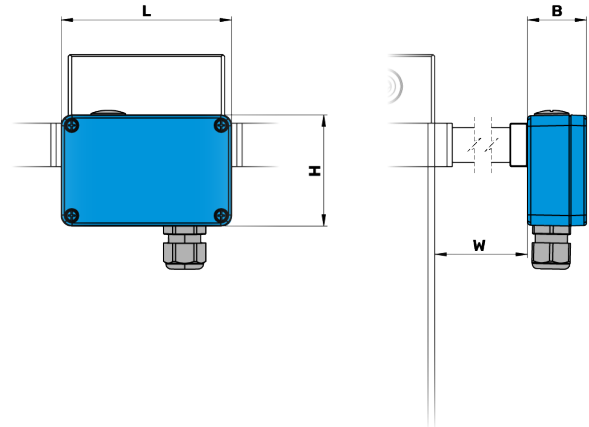

SM Terminal Box and Entire Enclosure Stainless Steel 316

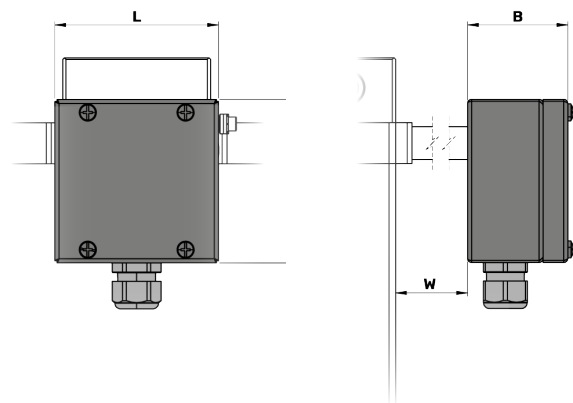

TM Integral PTFE Cable Instead of Terminal Box Standard Length 2 m. Can be extended up to max 10 m

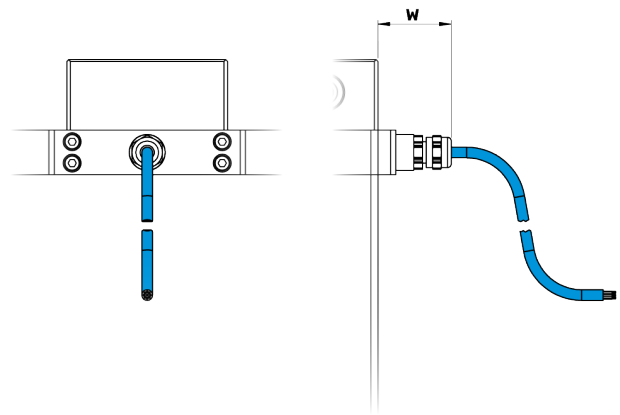

Electrical Connection Dimensions	mm	in
J5, JM Standard Box (L x H x B)	125 x 80 x 57	4.92 x 3.15 x 2.24
PM Compact Box (L x H x B)	98 x 64 x 34	3.86 x 2.52 x 1.34
SM SS316 Box (L x H x B)	100 x 100 x 61	3.94 x 3.94 x 2.40
TM Integral PTFE Cable (W)	41	1.61
Temperature Range N1, NA (W)	2	0.08
Temperature Range E2, E3, H4 (W)	100	3.94

JM, SM Terminal boxes are supplied with an M20 x 1.5 cable entry, optional entries are available
 PM Compact Terminal boxes are supplied with an M16 x 1.5 cable entry
 For integral transmitter version J5 please refer to RHE45 datasheet

Mounting Schemes

Standard/Usual Installation Without Mounting Brackets

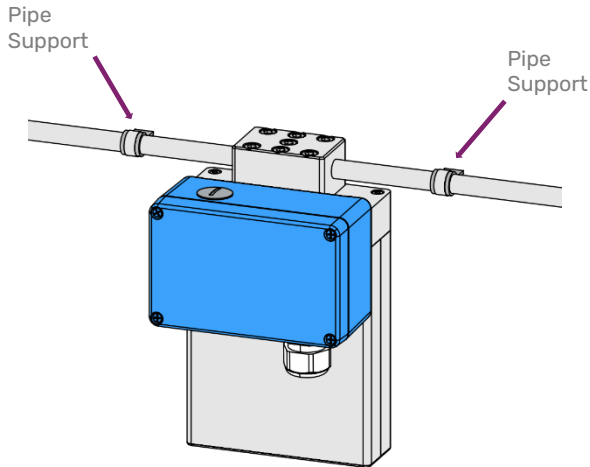

Thread dimensions base plate PMO (backside of the sensor)

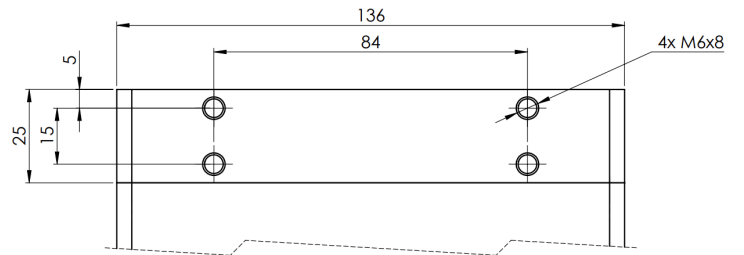

Mounting Aids for special Installation requirements

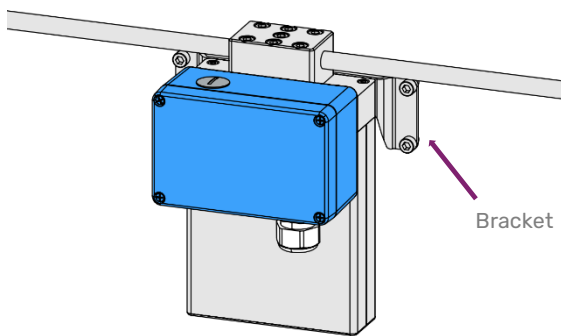

Type M - Wall Mount

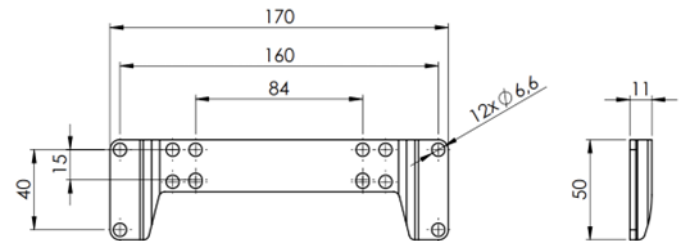

Type MF - Floor Mount

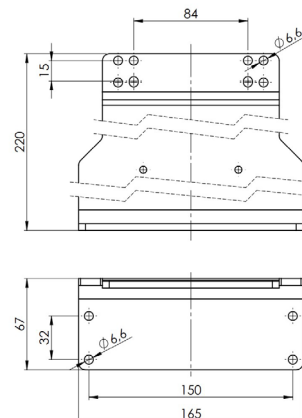

Transmitter Range

Any Rheonik Mass Flow Transmitter model can be combined with any Rheonik Mass Flow Sensor to provide an overall mass flow measurement system to suit any requirement. Rheonik Coriolis Transmitters are available in versions specifically designed for process, industrial and OEM applications. Economical blind front versions of some transmitters are available where displays and keypads are not required. The wide range of sensors and transmitters provide tremendous options for system designers and end users alike.

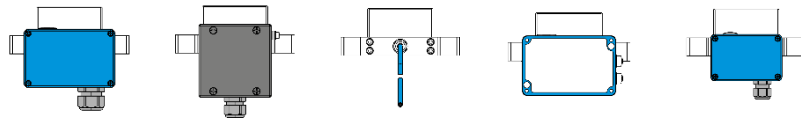

Product Code	JM	SM	TM	J5	PM
 RHE 21	✓	✓	✓	-	✓
 RHE 26	✓	✓	✓	-	✓
 RHE 27	✓	✓	✓	-	✓
 RHE 28	✓	✓	✓	-	✓
 RHE 42	✓	✓	✓	-	✓
 RHE 45	-	-	-	✓	-

RHM 04 Part Number Code

Temperature Range

- N1 NT from -20 to +120°C (-4 to +248°F)
- NA ET from -50 to +120°C (-58 to +248°F)
- E2 ET2 from -50 to +210°C (-58 to +410°F)
- E3 ET1 from -196 to +50°C (-321 to +122°F) - only sealless

Pressure Code for p_{max} of Measuring Loops

See pressure ratings page for ratings and codes

Construction Type - p_{max} indications refer to 120°C / 248°F

- PM0 Parallel block/manifold in SS316L with seals, p_{max} = 700 bar
- SM0 Serial block/manifold in SS316L with seals, p_{max} = 700 bar
- PH0 Parallel block/manifold in SS316L with seals, p_{max} = 1220 bar (20000 psi @ 50°C / 122°F) - only Autoclave
- SH0 Serial block/manifold in SS316L with seals, p_{max} = 1220 bar (20000 psi @ 50°C / 122°F) - only Autoclave
- PMT Parallel, sealless only for H2 applications, HP material only, p_{max} = 1000 bar - only with Autoclave 3/8" MP
- PFO Parallel tube, sealless - only with flange and hub connections
- PFT Parallel tube, sealless - only with thread connections

Material of Measuring Loops

- 35 Stainless Steel SS316L / EN 1.4435 / UNS S31603
- HP Sandvik HP160 (no EN / UNS no.)
- 10 SuperDuplex / EN 1.4410 / UNS S32750

Process Connection

See mechanical construction pages for available connections and codes

Electrical Connection to Transmitter

- JM Terminal Box coated Aluminum - M20 x 1.5 cable entry, see Accessories for others - not with Haz. Area A0
- J5 Alu Box ready for integrated RHE45 - temperature restrictions apply - only Haz. Area NN
- PM Extra compact Terminal Box coated Aluminium - M16 x 1.5 cable entry - not with Haz. Area A0, No Option T1
- SM Terminal Box and entire Enclosure/Housing in SS316 - M20 x 1.5 cable entry, see Accessories for others
- TM Integral PTFE cable to RHE, 2m - not with H4, Haz. Area A0. C0 only with N1, NA

Options Codes

See options listing for specific codes

Hazardous Area Certifications (details see page 19)

- NN Without Ex Approval
- A2 ATEX/IECEX Approvals Zone 2
- A1 ATEX/IECEX Approvals Zone 1 - requires suitably rated RHE
- A0 ATEX/IECEX Approvals Zone 0 - requires Elec. Conn. SM, suitably rated RHE
- C2 CSA Approval US-Canada Class I, Zone 2, Gas IIC
- C0 CSA Approval US-Canada Class I, Div.1 / Zone 0, Gas IIC - requires suitably rated RHE

Pressure Design Compliance

- NN Rheonik standard design based on EN codes (no PED - not for sales into EU)
- SE PED compliance according to SEP - Sound Engineering Practice

Performance Certification

- NN No Performance Certification
- AB ABS approval for marine applications - includes approval for RHE Transmitter
- R9 OIML R139 approval for hydrogen dispensers - requires RHE2x
- 9R OIML-CS R139 approval for hydrogen dispensers - requires RHE4x
- MH MID MI002 approval for H2 metering - requires RHE2x

Mass Flow, Density Calibration Selection

See performance page for code options

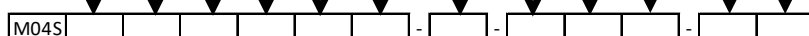

Options and Manufacturing Instruction Codes

Options Codes	
NN	Without Option
T1	Terminal box with cable entry upwards/gas installation
T0	Set-off terminal box for N1, NA Temperature Range (included in E2, E3, H4)
F0	FVMQ Seals for manifolds instead of standard seals / recommended for frequent use < 0 °C
FK	FFKM* Seals for manifolds instead of standard seals / high chemical resistance
P2	1/2" NPT Purge
RD	Enclosure with integrated rupture disk
PD	½" NPT Purge with integrated Rupture Disk (2 bar/29psi)

*FFKM seals minimum temperature is -20°C / -4°F

Instructions	
N	No manufacturing instructions
F	Removal of rest water from calibration with compressed air
7	Upgrade to dual rating IP66/67 - only with electrical connection SM
O	Special Cleaning, water and fat free
S	Sea-worthy packing

Additional separate choices

Options	Order Code ORHM-...
E1	Terminal box prepared for female thread ½" NPT cable entry
E2	Terminal box prepared for female thread M25 x 1.5 cable entry (only with Electrical Connection SM)
E3	Terminal box prepared for female thread ¾" NPT cable entry (only with Electrical Connection SM)
TP	Separate TAG Plate in Stainless Steel (TAG Information only)
TP-C	Type Label in Stainless Steel (TAG and all other label information)

Standard cable entry on JM, SM terminal box is M20 x 1.5. Cable entry on PM terminal box is always M16 x 1.5

Accessories	Order Code ARHM-...
M	Wall mounting bracket - recommended for sensitive, low flow installations
MF	Floor mounting bracket

Hazardous Area Certifications

Code	Zone / Division	Approval		Labeling
A0	Zone 0	ATEX		II 1G Ex ia IIC T6...T1 Ga
A1	Zone 1	ATEX		II 2G Ex ib IIC T6...T1 Gb
A2	Zone 2	ATEX		II 3G Ex ec IIC T6...T1 Gc
A0	Zone 0	IECEX		Ex ia IIC T6...T1 Ga
A1	Zone 1	IECEX		Ex ib IIC T6...T1 Gb
A2	Zone 2	IECEX		Ex ec IIC T6...T1 Gc
C0	Div 1, Zone 0	Zone USA/Canada		Class I, Div 1, Groups A, B, C and D T6...T1; Class I, Zone 0, AEx ia IIC T6...T1 Ga
C2	Zone 2	Zone USA/Canada		Class I, Zone 2, AEx nA IIC T6...T1 Gc



About Rheonik

Rheonik has but one single purpose: to design and manufacture the very best Coriolis meters available.

Our research and engineering resources are dedicated to finding new and better ways to provide cost effective accurate mass flow solutions that provide value to our customers. Our manufacturing group care for each and every meter we produce from raw materials all the way to shipping, and our service and support group are available to help you specify, integrate, start-up and maintain every Rheonik meter you have in service. Whether you own just one meter or have hundreds, you will never be just another customer to us. You are our valued business partner.

Need a specific configuration for your plant? Don't compromise with a "standard" product from elsewhere that will add extra cost to your installation. If we can't configure it from our extensive and versatile product range, our exclusive **AnyPipeFit Commitment** can have your flow sensor customized with any size/type of process connection and face to face dimension you need.

No matter what control system you use as the backbone in your enterprise, with our **AnyInterface Commitment**, you can be sure that connection and communication will not be a problem. Alongside a wide variety of discrete analog and digital signal connections, we can also provide just about any network/bus interface available (for example: HART, ProfibusDP, ProfiNet, EtherCAT, PowerLink, EtherNet/IP, CAN,) with our RHE 40 Series family of transmitters. Rheonik RHE 40 Series transmitters can connect to your system – no headache and no conversion needed.

Rheonik Messtechnik GmbH
Rudolf-Diesel-Straße 5
D-85235 Odelzhausen
Germany

Tel + 49 (0)8134 9341-0
Info@rheonik.com

